

**LS 55 Throughbeam photoelectric sensor for the detection of aqueous liquids**

en 03-2016/11 50127872-02

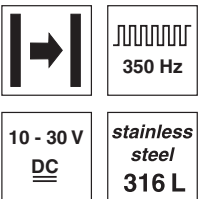

**0 ... 80m**

- Throughbeam photoelectric sensor for the detection of aqueous liquids in glass and plastic containers (bottles, syringes, trays, etc.)
- Radiation through transparent, colored glass and PET containers, even with printed plastic labels
- Model for monitoring the fill level with glass and plastic containers
- Power adaptation for container diameter 10 ... 300mm
- 316L stainless steel housing in WASH-DOWN-Design
- ECOLAB and CleanProof+ tested

We reserve the right to make changes • DS\_LS55H2O\_en\_50127872\_02.fm



**Accessories:**

(available separately)

- Cable with M8 or M12 connector (K-D ...)
- Cable for food and beverages
- Mounting devices

**Dimensioned drawing**

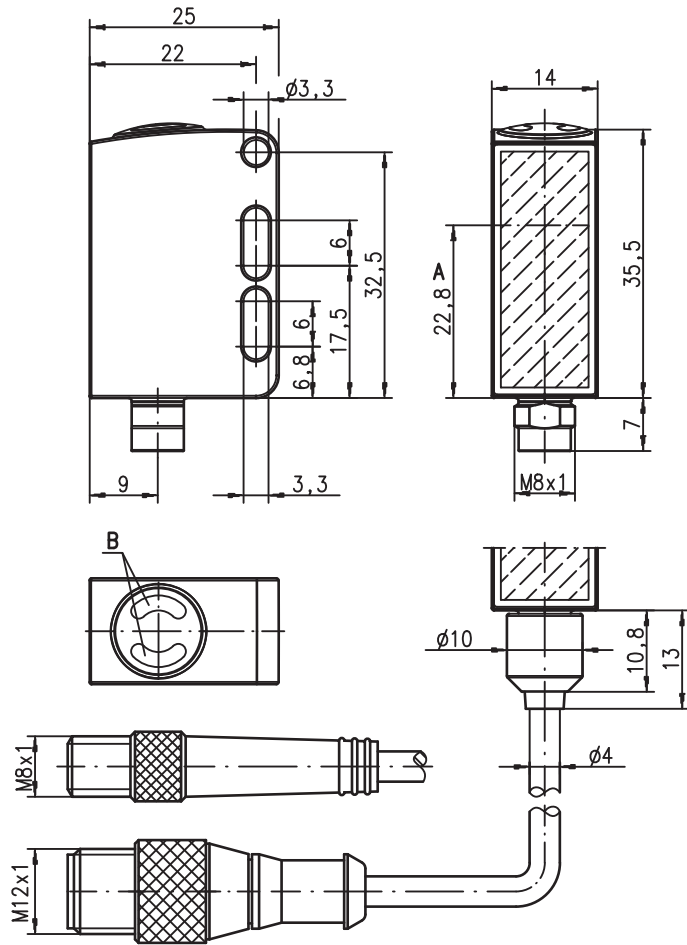

- A** Optical axis
- B** Indicator diodes

**Electrical connection**

Connector, 4-pin

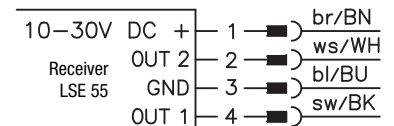
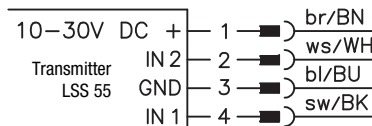

## Technical data

### Optical data

Typ. operating range limit <sup>1)</sup>	0 ... 80m
Operating range <sup>2)</sup>	0 ... 64m
Application range	0 ... 0.5m
Light source <sup>3)</sup>	LED (modulated light)
Wavelength	1450nm (infrared light)

### Timing

Switching frequency	350Hz
Response time	1.43ms
Readiness delay	≤ 300ms

### Electrical data

Operating voltage UB <sup>4)</sup>	10 ... 30VDC (incl. residual ripple)
Residual ripple	≤ 15% of UB
Open-circuit current	≤ 20mA (per sensor)
Switching output	.../44 2 PNP transistor switching outputs, antivalent pin 2: dark switching pin 4: light switching light/dark switching
Function	≥ (UB-2V) ≤ 2V
Signal voltage high/low	max. 100mA
Output current	adjustable on the transmitter via pin 2 and pin 4
Sensitivity	

### Indicators

Green LED	ready
Yellow LED	light path free

### Mechanical data

Housing	AISI 316L stainless steel, DIN X2CrNiMo17132, W.No1.4404
Housing design	WASH-DOWN design
Housing roughness <sup>5)</sup>	Ra ≤ 2.5
Connector	AISI 316L stainless steel, DIN X2CrNiMo17132, W.No1.4404
Optics cover	coated plastic (PMMA), scratch resistant and non-diffusive
Operation	plastic (TPV-PE), non-diffusive
Weight	with M8 connector: 40g with 200mm cable and M12 connector: 60g with 5000mm cable: 110g
Connection type	M8 connector, 3-pin or 4-pin, 0.2m cable with M12 connector, 4-pin, 5m cable, 4 x 0.20mm <sup>2</sup>

### Environmental data

Ambient temp. (operation/storage) <sup>6)</sup>	-30°C ... +65°C/-30°C ... +70°C
Protective circuit <sup>7)</sup>	2, 3
VDE safety class <sup>8)</sup>	III
Degree of protection	IP 67, IP 69K <sup>9)</sup>
Environmentally tested acc. to	ECOLAB, CleanProof+
Light source	exempt group (in acc. with EN 62471)
Standards applied	IEC 60947-5-2
Certifications	UL 508, C22.2 No.14-13 <sup>4)</sup> <sup>10)</sup>
Chemical resistance	tested in accordance with ECOLAB and CleanProof+ (see Remarks)

### Additional functions

#### Transmitter sensitivity (see Sensitivity adjustment)

Pin 2 active/not active	≥ 8V/≤ 2V
Pin 4 active/not active	≥ 8V/≤ 2V
Activation delay	≤ 1ms
Input resistance	30kΩ

- 1) Typ. operating range limit: max. attainable range without function reserve in transmitting level 4
- 2) Operating range: recommended operating range with function reserve in transmitting level 4
- 3) Average life expectancy 100,000h at an ambient temperature of 25°C
- 4) For UL applications: use is permitted exclusively in Class 2 circuits according to NEC
- 5) Typical value for the stainless steel housing
- 6) Operating temperature in transmitting level 4 is limited to -30°C ... +55°C
- 7) 2=polarity reversal protection, 3=short circuit protection for all transistor outputs
- 8) Rating voltage 50V
- 9) Only in combination with M12 connector
- 10) These proximity switches shall be used with UL Listed Cable assemblies rated 30V, 0.5A min, in the field installation, or equivalent (categories: CYJV/CYJV7 or PVVA/PVVA7)

## Tables

0	64	80
---	----	----

□	Operating range [m]
□	Typ. operating range limit [m]

## Diagrams

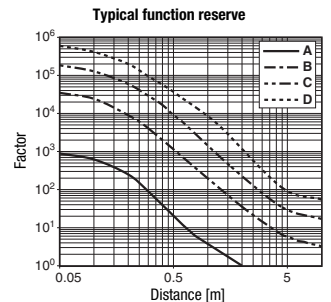

- A Sensitivity level 1
- B Sensitivity level 2
- C Sensitivity level 3
- D Sensitivity level 4

## Remarks

### Observe intended use!

- ⚠ This product is not a safety sensor and is not intended as personnel protection.
- ⚠ The product may only be put into operation by competent persons.
- ⚠ Only use the product in accordance with the intended use.

- Colored liquids and labels increase the damping
- The function reserve can be adjusted on the transmitter (pin 2 + pin 4)
- The function reserve can be reduced by misaligning the receiver
- A light axis consists of a transmitter and a receiver with the following designations:

LS = Complete light axis  
LSS = Transmitter  
LSE = Receiver

- A list of tested chemicals can be found in the first part of the product description.

### UL REQUIREMENTS

Enclosure Type Rating: Type 1

**For Use in NFPA 79 Applications only.**

Adapters providing field wiring means are available from the manufacturer. Refer to manufacturers information.

**CAUTION** – the use of controls or adjustments or performance of procedures other than those specified herein may result in hazardous radiation exposure.

**ATTENTION** ! Si d'autres dispositifs d'alignement que ceux préconisés ici sont utilisés ou s'il est procédé autrement qu'indiqué, cela peut entraîner une exposition à des rayonnements et un danger pour les personnes.

## LS 55 Throughbeam photoelectric sensor for the detection of aqueous liquids

### Order guide

Selection table		Order code →		
Equipment ↓		Detection of aqueous liquids	Customer-specific version	Fill-level monitoring
		LS 55/44.H2O, 200-S12 Part no. 50127771 (Tr) Part no. 50127772 (Re)	LS 55/44.H2O.K, 200-S12 Part no. 50135166 (Tr) Part no. 50135165 (Re)	LS 55/441.H2O,200-S12 Part no. 50127771 (Tr) Part no. 50130550 (Re)
Switching output	2 x PNP transistor output, antivalent	●	●	●
Switching function	Pin 4: light switching	●	●	●
	Pin 2: dark switching	●	●	●
Connection	M8 connector, metal, 4-pin			
	M8 connector, metal, 3-pin			
	Cable 200mm with M12 connector, metal, 4-pin	●	●	●
	Cable 5000mm, 4-wire			
Indicators	Green LED: ready	●	●	●
	Yellow LED: switching output	●	●	●
Features	Activation input			
	Sensitivity switch-over on the transmitter	●	●	●
	Receiver for detection of aqueous liquids	●	●	
	Receiver for fill-level monitoring			●
	Customer-specific version		●	

### Detection of aqueous liquids in glass and plastic containers (bottles, syringes, trays, etc.)

#### Recommendation for the sensitivity adjustment on the transmitter

Transmitter pin 4	Transmitter pin 2	Sensitivity	Distance transmitter/receiver <sup>1)</sup>	Formats <sup>2) 3)</sup>
Not connected or 0V	$U_B$	Level 1 (min.)	50 ... 100mm	Container < 0.5l, clear ... colored, without label
Not connected or 0V	Not connected or 0V	Level 2 (default)	100 ... 500mm	Container 0.1 ... 2l, clear ... colored, without label
$U_B$	$U_B$	Level 3	100 ... 500mm	Container 0.1 ... 5l, clear ... colored, without label
$U_B$	Not connected or 0V	Level 4 (max.)	100 ... 500mm	Container 0.1 ... 5l, clear ... colored, with label <sup>4)</sup>

- 1) Additional reduction of the sensitivity by misaligning the receiver
- 2) Typical details, strong dependence on container color and water column diameter
- 3) Other containers and foils depending on material and sensor distance
- 4) Plastic labels, also with printing

**Notice on correct alignment and sensitivity selection**

1. Mount transmitter and receiver. For receiver, provide for possibility of tilting 0° ... 15°. The bottles should not be detected directly in front of the receiver. Observe the following installation recommendation:

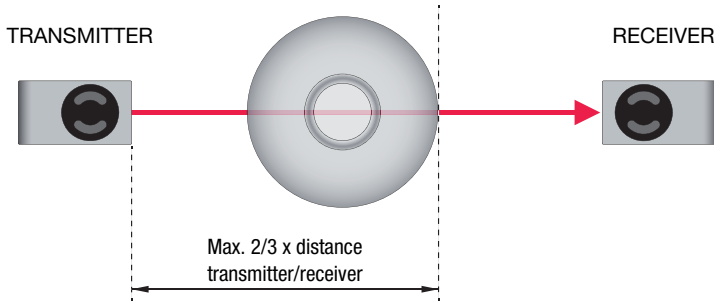

2. Exactly align the optical axis.
3. Rough adjustment of the sensitivity on the transmitter according to the sensitivity table.

**Rough adjustment of the sensitivity**

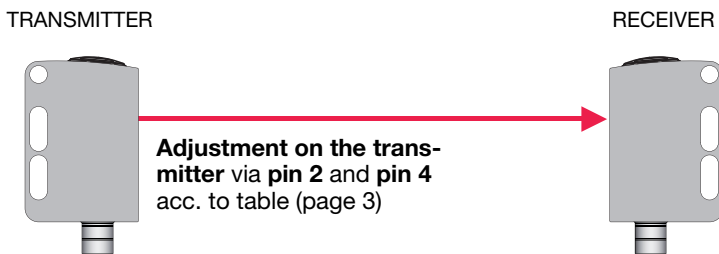

4. Check: empty bottle must not result in interruption. In the event of interruption: increase sensitivity (on transmitter: pin 2, pin 4) or reduce the transmitter/receiver distance.
5. Filled bottle must consistently result in interruption. Otherwise, reduce the sensitivity (on transmitter: pin 2, pin 4) and/or fine tune the sensitivity.

**Fine tuning the sensitivity**

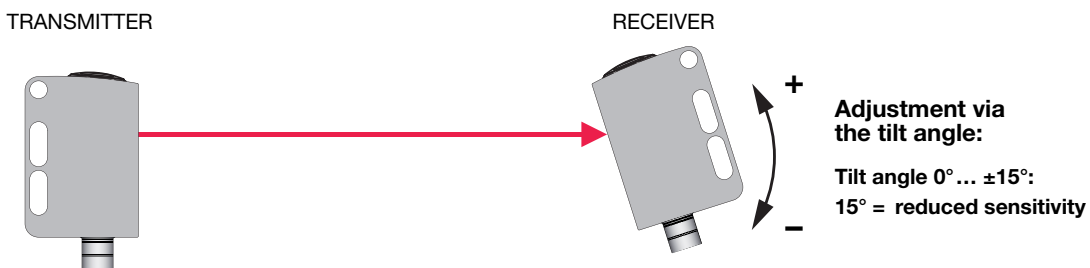

## LS 55 Throughbeam photoelectric sensor for the detection of aqueous liquids

### Fill-level monitoring with glass and plastic containers

The photoelectric sensor can be used to determine fill levels during the filling of containers with beverages (e.g., water, fruit juices, beer, wine, milk) or aqueous solutions (e.g., cleaners, acids, bases, alcohols).

#### Recommendation for the sensitivity adjustment on the transmitter

A transmitter adjustment is not normally necessary, i.e., inputs **IN1** and **IN2** on the transmitter remain disconnected. If the sensor does not generate a switching signal with this setting, the transmitting power must be reduced to **level 1 (min.)** according to the **table on page 3** "Recommendation for the sensitivity adjustment on the transmitter".

#### Notice on correct alignment of the photoelectric sensor

In principle, transmitter and receiver can be mounted at any distance to the container. If feasible, we recommend a distance of 10 - 40 mm.

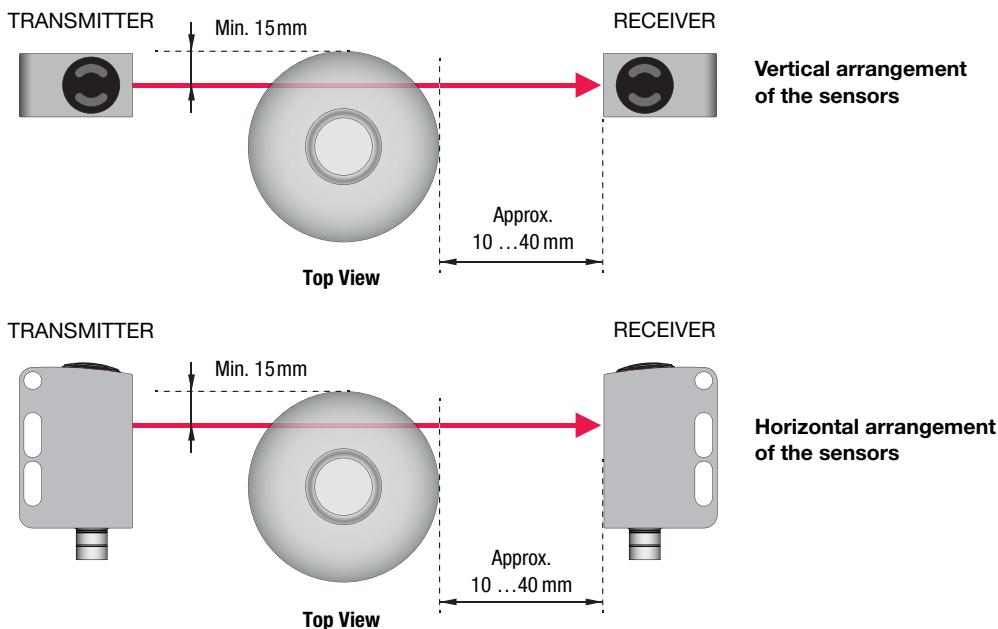

1. The optical axis of transmitter and receiver must be exactly oriented horizontally as well as vertically.  
Refer to the dimensioned drawing on page 2 for the orientation of the optical axis.
2. At the position where the fill level is to be monitored, the light beam must not be directed through the filling beam.
3. The optical axis must pass through the bottle at a distance of at least 15 mm from the outer wall of the container.
4. The fill-level monitoring is largely independent of the bottle geometry, thickness or color. If the surface of the liquid is smooth and level during the filling process, very good reproducibility of typically 0.2 to 0.5 mm can be achieved.  
The more wavy or turbulent the surface of the liquid is during the filling process, the lower the reproducibility.  
No generalizations can be made here; values must be determined through practical trials.

